

Installation Guide



Grid Tie Interface (GTI)

SW Series

SW4024, SW4048, SW5548

About Xantrex

Xantrex Technology Inc., is a world-leading supplier of advanced power electronics and controls with products from 50 watt mobile units to 1 MW utility-scale systems for wind, solar, batteries, fuel cells, microturbines, and backup power applications in both grid-connected and stand-alone systems. Xantrex products include inverters, battery chargers, programmable power supplies, and variable speed drives that convert, supply, control, clean, and distribute electrical power.

Trademarks

Trace and Xantrex are registered trademarks of Xantrex International.

Notice of Copyright

Grid Tie Interface (GTI) Owner's Manual © November 2001 Xantrex Technology Inc. All rights reserved.

Disclaimer

While every precaution has been taken to ensure the accuracy of the contents of this guide, Xantrex International assumes no responsibility for errors or omissions. Note as well that specifications and product functionality may change without notice.

Since the use of this manual and the conditions or methods of installation, operation, use and maintenance of the unit are beyond the control of Xantrex Technology Inc., the company does not assume responsibility and expressly disclaims liability for loss, damage, or expense arising out of or any way connected with such installation, operation, use, or maintenance.

Due to continual improvement through product updates, photographs and/or illustrations used in this manual may not *exactly* match your unit. Xantrex Technology Inc., reserves the right to update this product without notice or releasing an updated manual when *fit, form or function* are not affected.

Date and Revision

January 2002, Revision A

Part Number

975-0041-01-01

Contact Information

Web:	www.xantrex.com
Email:	dpm@xantrex.com
Phone:	360/435.8826
Fax:	360/435.2229

IMPORTANT SAFETY INSTRUCTIONS

This manual contains important safety instructions that should be followed during the installation and maintenance of this product.

To reduce the risk of electrical shock, and to ensure the safe installation and operation of this product, the following safety symbols have been placed throughout this manual to indicate dangerous conditions and important safety instructions.



WARNING - A DANGEROUS VOLTAGE OR CONDITION EXISTS IN THIS AREA. USE EXTREME CAUTION WHEN PERFORMING THESE TASKS.

AVERTISSEMENT - UNE TENSION OU CONDITION DANGEREUSE EXISTE DANS CETTE ZONE. FAIRE PREUVE D'EXTRÊME PRUDENCE LORS DE LA RÉALISATION DE CES TÂCHES.



CAUTION - This procedure is critical to the safe installation or operation of the unit. Follow these instructions closely.

ATTENTION - Cette procédure est essentielle à l'installation ou l'utilisation de l'unité en toute sécurité. Suivre ces instructions de près.



NOTE - This statement is important. Follow instructions closely.

NOTE - Cette déclaration est importante. Suivre les instructions de près.

- All electrical work must be done in accordance with local, national, and/or international electrical codes.
- Before installing or using this device, read all instructions and cautionary markings located in the manual, and on the inverter, the batteries, and the PV array.
- Do not expose this unit to rain, snow or liquids of any type. This product is designed only for indoor mounting.
- To reduce the chance of short-circuits when installing or working with the inverter, the batteries, or the PV array, use insulated tools.
- Remove all jewelry while installing this system. This will greatly reduce the chance of accidental exposure to live circuits.

IMPORTANT SAFETY INSTRUCTIONS (Continued)

- The unit contains more than one live circuit (inverter and utility grid). Power may be present at more than one source.
- This product contains no user-serviceable parts. Do not attempt to repair this unit.
- To reduce risk of electric shock, disconnect all wiring before attempting any maintenance or cleaning. Turning off the device may not reduce this risk. As long as AC input power is present, the charger section will be operable regardless of the ON/OFF switch position.
- Do not mount this device in unventilated enclosures.
- To reduce risk of electric shock, disconnect all wiring before attempting any maintenance or cleaning.
- Additional AC disconnects may be required as part of the system installation. Consult local and national electrical code requirements.
- This unit is designed to be horizontally wall mounted.
- The AC input and output neutral conductors are not connected (bonded) to the chassis.
- The AC input and output HOT conductor are not isolated from each other.
- The chassis housing of the GTI must be connected to a permanent grounding system as required by the National Electric Code, ANSI/NFPA 70-1996. This is the responsibility of the system installer. A grounding terminal lug is provided for connection of an equipment grounding conductor.
- CSA listed for sale in the U.S. under Photovoltaic Power Systems (UL1741).

SAVE THESE INSTRUCTIONS

Contents

IMPORTANT SAFETY INSTRUCTIONS	iii
1.0 INTRODUCTION	1
Introduction	1
Standard Features	3
Utility Interactive Mode	3
Bypass Mode	3
2.0 INSTALLATION	5
Pre-Installation	5
Required Tools	5
Removing the Top Cover	5
Mounting	5
Procedure	6
Wiring	9
AC Wiring for Single Inverter Installation	10
AC Input Wiring from the Utility Grid to the GTI	10
AC Input Wiring from the GTI to the Inverter	10
AC Output Wiring from the Inverter to the Sub-Panel	11
Communications Cable	11
AC Wiring for Dual Inverter Installation	13
Ground Wiring (See Figure 2-8)	14
AC Wiring from the Utility Grid to the GTIs (See Figure 2-8)	14
AC Wiring from the GTIs to the Inverters (See Figure 2-8)	15
Generator Wiring (See Figure 2-8)	15
Inverter Output Wiring (See Figure 2-8)	15
Communications Cables	16
Operating Stacked Inverters	17
Start-up and Test	17
Wiring Check	18
3.0 TROUBLESHOOTING	19
APPENDIX A – SPECIFICATIONS	A-1
Electrical Specifications	A-1
Mechanical Specifications	A-1
APPENDIX B – PRODUCT AND SYSTEM INFORMATION	B-1
Warranty	B-1
Return Material Authorization Policy	B-2
Return Material Procedure	B-2
Service Information	B-3

List of Figures

Figure 1-1 – Grid Tie Interface	2
Figure 1-2 – Grid Tie Interface Unit	3
Figure 2-1 – Removing the Top Cover	5
Figure 2-2 – Mounting Holes	6
Figure 2-3 – Dimensional Drawing (Not to scale)	7
Figure 2-4 – GTI Circuit Board Enlargement	8
Figure 2-5 – Wiring Diagram	9
Figure 2-6 – GTI Communications Cable Location	11
Figure 2-7 – Connecting the Communications Cable to the Circuit Board ..	12
Figure 2-8 – Wiring Diagram for Dual Inverter Installations	13

INTRODUCTION

The Grid Tie Interface (GTI) is an integrated assembly used with the Trace™ SW Series II inverter/charger with Revision 4.2 software. This new device provides active anti-islanding protection and reduces current Total Harmonic Distortion (THD) below the test requirements as described in UL-1741-2000.

The Grid Tie Interface is an accessory, which is connected between the grid and the SW Series II inverter to optimize the “SELL” feature. While there is a small inductor in the GTI, this device is not a “filter”; rather it contains an additional control microprocessor, which connects to the SW Series II with a communications cable.

When the GTI is connected and the Inverter “SELL” mode is selected, the microprocessor of the GTI takes control of the SW Series II and operates the inverter “SELL” feature. The GTI affords a dedicated microprocessor and new, sophisticated control algorithms that are able to optimize the sell function.

The SW Series II /GTI meets all power quality requirements of UL1741, including harmonic distortion, power factor, and anti-islanding requirements. In addition, it has increased the SW Series II's efficiency in SELL mode to within 1% of the impressive off-grid efficiency of the SW.

The GTI also contains an automatic transfer/shorting relay, which the SW Series II uses to disconnect the GTI from the circuit when it is not needed, for example when the SW Series II is charging batteries from the grid. This is also used to disconnect the GTI so that it does **NOT** represent a phantom load or parasitic loss to the system.

During a blackout or any time the SW Series II is powering house loads directly, the GTI is not in the power circuit and thus does not represent an efficiency loss.

All new SW Series II units (shipped since December of 2001) are equipped to allow the GTI to be installed in the field. The SW Series II inverter is Certified to UL1741 for off grid and backup power applications. The SW can be connected to the grid as a battery charger; however, it is **NOT** approved to use the SELL feature (net meter) without the GTI accessory. The GTI carries all necessary approvals and markings to allow a safety inspector to approve the installation for net metering.

1.0 INTRODUCTION

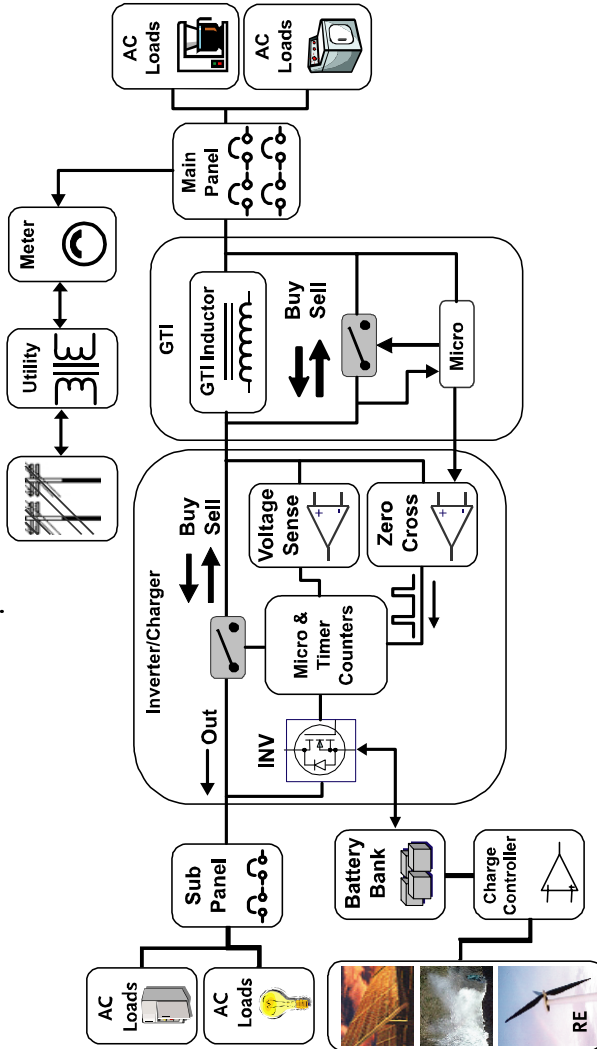

Figure 1-1
Grid Tie Interface

1.0 INTRODUCTION

STANDARD FEATURES

The Grid Tie Interface (GTI) is an external unit that is required for use with the Xantrex SW Series Inverters, models SW4024, SW4048, and SW5548 with Rev. 4.2 firmware only, being used in Utility Interactive “Sell” mode. This device ensures compliance with regulatory standards for utility interface applications.

The GTI utilizes a highly-efficient inductor constructed of high temperature materials and M-6 grade steel laminations, meeting UL Class-H standards.

The unit is housed in a powder-coated, steel enclosure, suitable for indoor installations and contains dual knockouts for $\frac{3}{4}$ " - 1" and $\frac{1}{2}$ " - $\frac{3}{4}$ " conduit connections. The unit includes a control board with one 10-pin, polarized, connector that connects to the SW inverter.

The GTI has two functions: 1) Utility Interactive Mode, and 2) Bypass Mode.

Utility Interactive Mode

Utility Interactive Mode is only engaged when the SW inverter begins selling power in the “Sell” mode. When in this mode, the GTI engages an inductor that filters out current harmonics and ensures that the power transferred to the grid has Total Harmonic Distortion (THD) levels that are within acceptable ranges and ensures the power factor is high. The GTI also provides anti-islanding protection in the event of a utility grid failure.

Bypass Mode

When the “Sell” current drops to a low level, the GTI will close the bypass relay to remove the filter from the circuit.



Figure 1-2
Grid Tie Interface Unit

PRE-INSTALLATION

The GTI is only designed to work with the SW4024, SW4048 and SW5548 models that have revision 4.2 (or higher) software. Prior to installing the GTI, ensure that you have the appropriate model, the proper level of software and the inverter has the communication cable located within. See Figure 2-6 for the location of this cable.

Required Tools

- Wire strippers
- Phillips screw driver
- Slotted screw driver
- Torque wrench

Removing the Top Cover

1. Remove the four Phillips screws and starwashers and set aside. Be sure to put these screws and washers somewhere where they can't get lost.



Figure 2-1
Removing the Top Cover

MOUNTING

Place the GTI in a convenient location, close to the inverter. The GTI must be mounted horizontally on a flat surface (such as a wall) in a clean, dry environment. Do not mount the GTI where it will be exposed to the weather or in a wet location.



NOTE: *The GTI weighs approximately 25 pounds. Use appropriate wall anchors or backing material (plywood, 2 x 4's, etc.) that will support its weight.*



CAUTION: *Do not mount vertically as water may enter the enclosure and damage the internal circuitry. Damage caused by mounting the unit vertically is NOT covered under the limited warranty.*

2.0 INSTALLATION

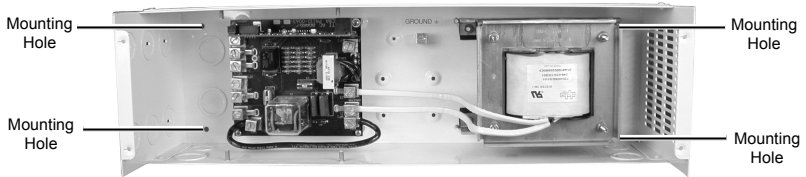
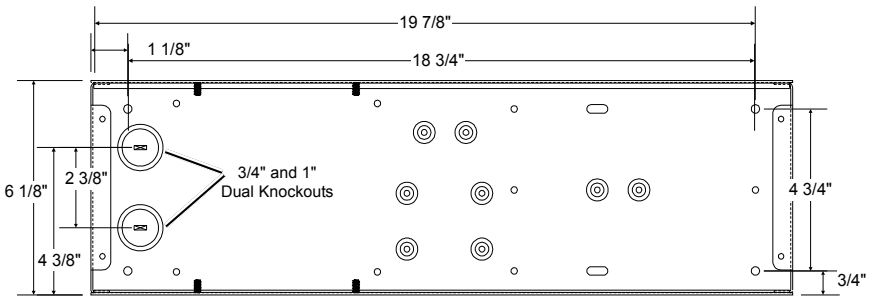

Figure 2-2
Mounting Holes

Procedure

- Use a level and mark the location for mounting the unit on the wall.
- Measure out the four mounting screw holes according to Figure 2-2.
- Drill out the mounting holes using a #18 (0.170 inch) drill bit.
- Use a #10 x 3/8 (or 1/2) inch long screw and washer (and appropriate anchors if necessary) and mount the GTI securely to the wall or backing material (plywood, 2 x 4's, etc.).
- Remove the appropriate knockouts for the conduit. Install the conduit between the GTI and the inverter. Use separate conduit for input and output wiring.

2.0 INSTALLATION



Back of unit

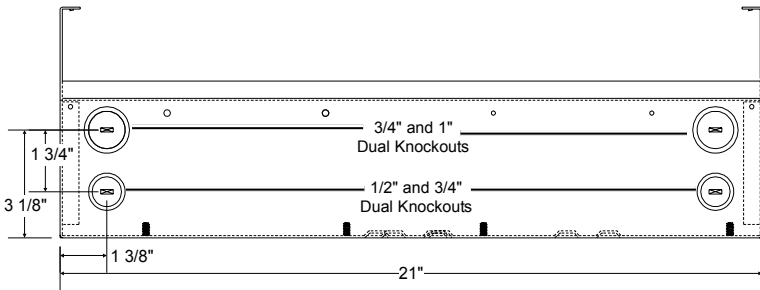

Front of unit

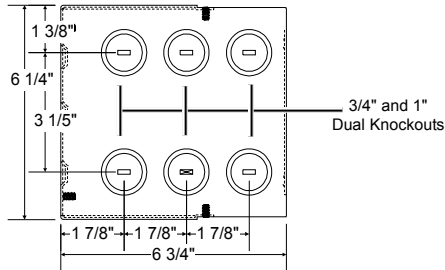

End of unit

Figure 2-3
Dimensional Drawing (Not to scale)

2.0 INSTALLATION

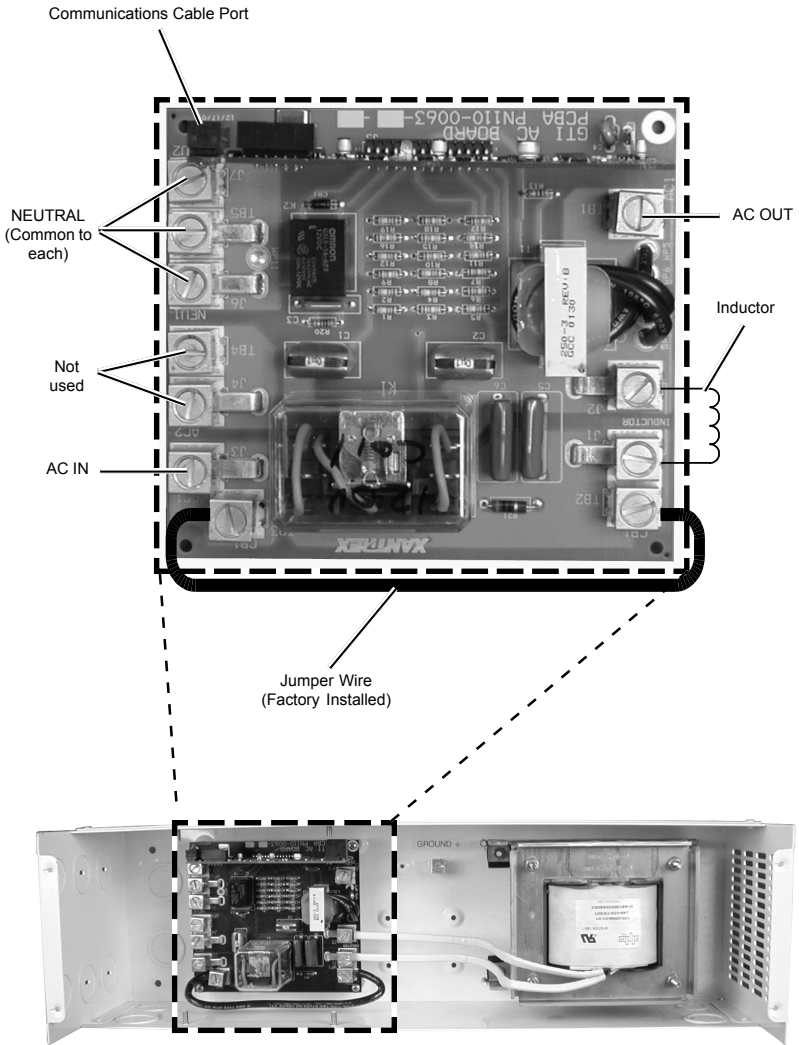

Figure 2-4
GTI Circuit Board Enlargement

WIRING

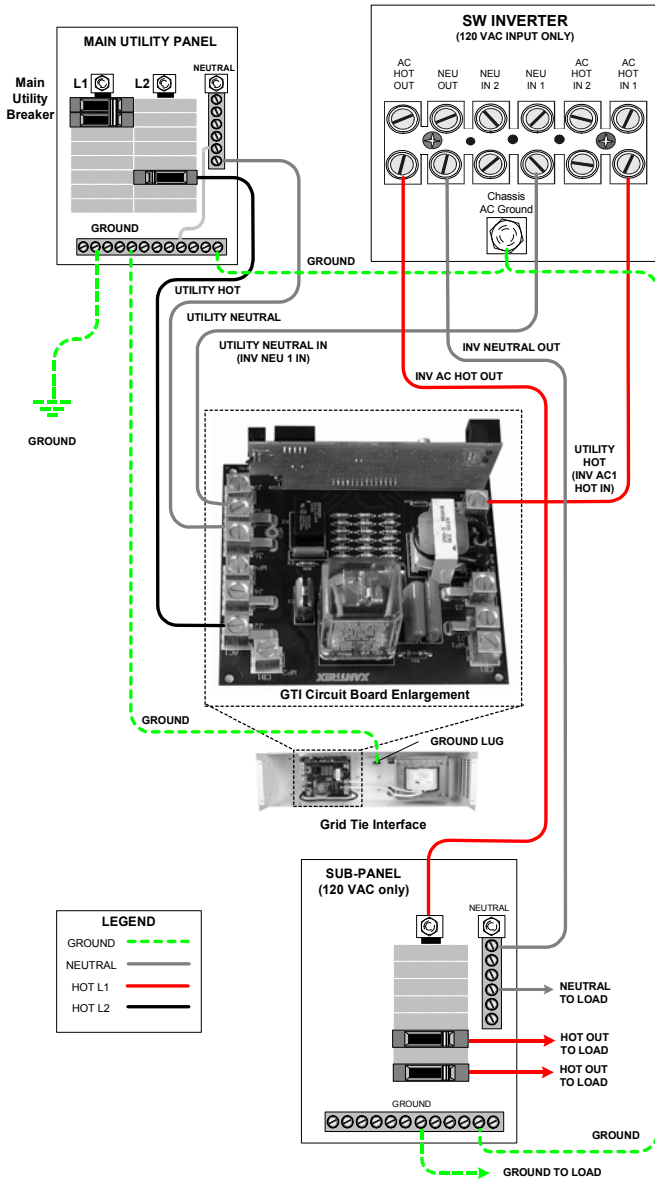

Figure 2-5
Wiring Diagram

2.0 INSTALLATION

Wiring (continued)

AC Wiring for Single Inverter Installation



NOTE: All wiring should be performed by a qualified person or a licensed electrician.

AC Input Wiring from the Utility Grid to the GTI



WARNING: DISCONNECT THE BATTERIES FROM THE INVERTER IF THEY ARE ALREADY CONNECTED.

1. Feed the HOT, NEUTRAL and GROUND input wires (via conduit) from the GTI to the main utility panel. Leave a sufficient amount of extra wire at each end.
2. Make the connections to the GTI first.



NOTE: Wiring to the main utility panel is performed after all connections have been made in the inverter.

- a. Connect a GROUND (green) wire from the main utility panel to the GTI's AC GROUND lug.
 - b. Connect the NEUTRAL (white) wire from the main utility panel to the GTI's NEUTRAL IN 1 terminal.
 - c. Connect the HOT (BLACK) wire from the main utility panel to the GTI's AC1 HOT IN terminal.
3. Torque all connections to 10 to 15 inch-pounds.

AC Input Wiring from the GTI to the Inverter

1. Feed the HOT, NEUTRAL and GROUND input wires (via conduit) from the inverter to the GTI. Leave three to six inches of extra wire at each end.
2. Make the connections to the inverter first.



NOTE: Wiring to the GTI is performed after all connections have been made in the inverter.

- a. Connect the GROUND (green) wire to the inverter's AC GROUND lug.
 - b. Connect the NEUTRAL (white) wire from the GTI's NEU OUT terminal to the inverter's NEUTRAL IN 1 terminal.
 - c. Connect the AC1 HOT OUT (BLACK) wire from the GTI to the inverter's AC1 HOT IN terminal.
3. Torque all connections to 10 to 15 inch-pounds.

Wiring (continued)

AC Wiring for Single Inverter Installation (continued)

AC Output Wiring from the Inverter to the Sub-Panel



WARNING: ENSURE THE SUB-PANEL DOES NOT HAVE A NEUTRAL-TO-GROUND BOND. IF IT DOES, REMOVE IT. ALL AC NEUTRAL-GROUND BONDING IS DONE AT THE MAIN UTILITY PANEL.

1. Connect the GROUND wire to the inverter's AC GROUND chassis terminal. Connect the other end of this wire to the GROUND bus in the sub-panel.
2. Connect the NEUTRAL (white) wire to the inverter's NEUTRAL OUTPUT terminal. Connect the other end of this wire to the NEUTRAL bus in the sub-panel.
3. Connect the HOT (black) wire to the inverter's terminal labeled AC HOT OUTPUT.
4. Connect a wire from the inverters HOT OUT terminal to the sub-panel's HOT IN terminal.
5. Torque all the inverter's connections to 10 to 15 inch-pounds. Refer to the sub-panel manufacturer's specifications for wire torques on the sub-panel connections.

Communications Cable

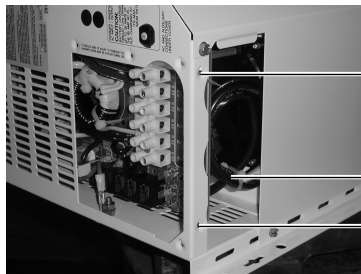

Remove this screw to remove the access panel.

Communications Cable

Remove this screw to remove the access panel.

Figure 2-6
GTI Communications Cable Location

1. Remove the access panel on the bottom of the inverter.
2. Clip the cable binding and gently remove the loose end of the communications cable from inside of the inverter. It will be located directly behind the AC Terminal Block.
3. Connect the loose end of the communications cable to the communications cable port on the GTI circuit board. See Figure 2-7.

2.0 INSTALLATION

Wiring (continued)

AC Wiring for Single Inverter Installation (continued)

Communications Cable (continued)

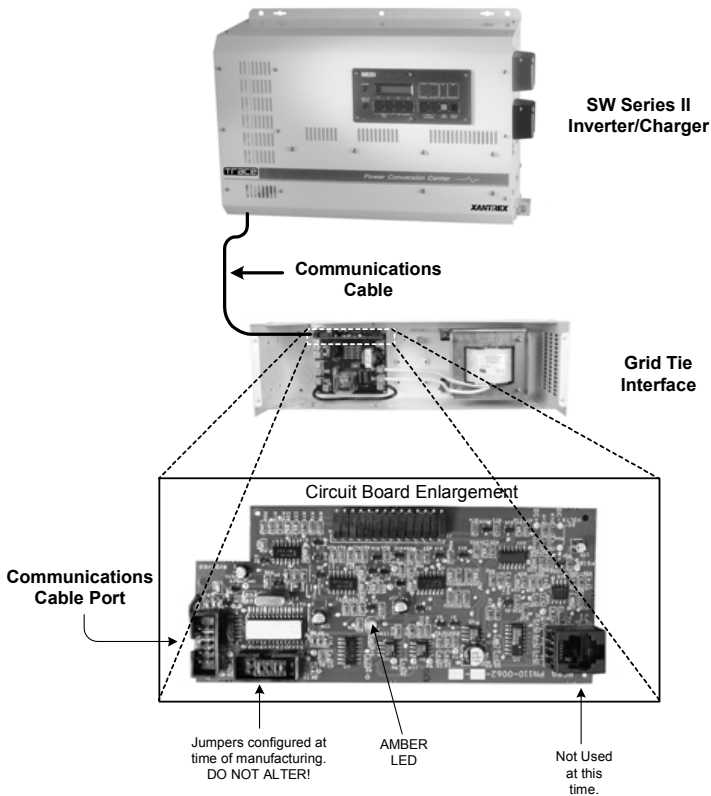



Figure 2-7
Connecting the Communications Cable to the Circuit Board

 **NOTE:** An additional 8-foot 10-conductor extension cable is available at Xantrex (P/N 130-0118-01-01) for installations where the inverter is more than 2 feet away from the GTI.

Wiring (continued)

AC Wiring for Dual Inverter Installation

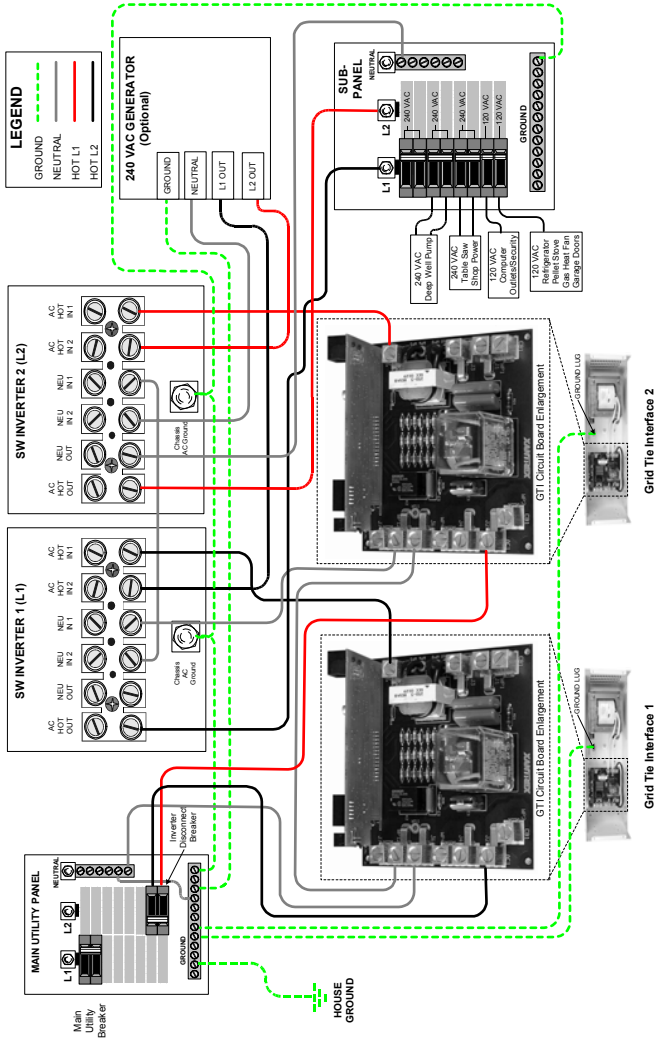

Figure 2-8
Wiring Diagram for Dual Inverter Installations

2.0 INSTALLATION

Wiring (continued)

AC Wiring for Dual Inverter Installations (continued)

Series stacking is used in applications where either 240-volt loads (or a combination of both 240- and 120-volt loads) need to be powered from the inverters. One inverter, connected to the utility's L1 line, provides one 120 volt AC output and a second inverter connected to the utility's L2 line provides the second 120 volt AC output (180 degrees out-of-phase from the first inverter). The combined out-of-phase voltages can power 240 volt AC loads as well as 120 volt loads, up to the power rating of the inverters.



NOTE: For full pass-through capability of the inverter, #6 AWG (90°C) minimum is recommended. Protect the wire with an appropriately sized breaker.

Ground Wiring (See Figure 2-8)

1. Connect a wire from the ground bus in the main service panel to the GROUND terminal in the GTI-1.
2. Connect a wire from the ground bus in the main service panel to the GROUND terminal in the GTI-2.
3. Connect a wire from the ground bus in the main service panel to the GROUND terminal in the L1 inverter.
4. Connect a wire from the ground bus in the main service panel to the ground terminal in the generator.

AC Wiring from the Utility Grid to the GTIs (See Figure 2-8)

1. Connect a wire from the neutral bus in the main service panel to the NEUTRAL IN terminal in the GTI-1.
2. Connect a wire to the NEUTRAL OUT terminal on the GTI-1 and route this wire to the GTI-2's NEUTRAL IN terminal. Keep this wire as short as possible.
3. Connect a wire from the main service panel's hot L1 line to the GTI-1's AC HOT IN 1 terminal.
4. Connect a wire from the main service panel's hot L2 line to the GTI-2's AC HOT IN 1 terminal.

Wiring (continued)

AC Wiring for Dual Inverter Installations (continued)

AC Wiring from the GTIs to the Inverters (See Figure 2-8)

1. Connect a wire from the NEUTRAL OUT terminal in GTI-2 to the NEUTRAL IN 1 terminal in the L1 inverter.
2. Connect a wire from the GTI-1's AC HOT OUT to the L1 inverter's AC HOT IN 1 terminal.
3. Connect a wire from the GTI-2's AC HOT OUT to the L2 inverter's AC HOT IN 1 terminal.

Generator Wiring (See Figure 2-8)

1. Connect a wire from the generator's neutral terminal to the NEUTRAL IN 2 terminal in the L2 inverter.
2. Connect a wire from the generator's L1 HOT OUT terminal (120 VAC) to the AC HOT IN 2 terminal in the L1 inverter.
3. Connect a wire from the generator's L2 HOT OUT terminal to the AC HOT IN 2 terminal in the L2 inverter.

Inverter Output Wiring (See Figure 2-8)

The output of each inverter provides 120 VAC. The voltage between the HOT outputs from the L1 and L2 inverter is 240 VAC.

1. Connect a NEUTRAL wire from the L1 inverter NEUTRAL IN 1 terminal to the L2 inverter NEUTRAL IN 1 terminal.
2. Connect the NEUTRAL wire from the L1 (or L2) inverter's NEUTRAL OUT terminal to the neutral bus in the sub-panel.
3. Connect the AC HOT OUTPUT (120 VAC) from the L1 inverter to the L1 terminal in the sub-panel.
4. Connect a wire from the ground terminal in inverter L1 to the GROUND terminal in the inverter L2.
5. Connect the AC HOT OUTPUT (120 VAC) from the L2 inverter to the L2 terminal in the sub-panel.
6. Connect a wire from the ground terminal in inverter L2 to the sub-panel.



WARNING: ENSURE THE ONLY NEUTRAL-TO-GROUND BOND IS IN THE MAIN UTILITY PANEL. REMOVE ANY BONDING FROM THE SUB-PANEL IF IT IS PRESENT.

2.0 INSTALLATION

Communications Cables

See Figure 2-6 for the location of the communications cable inside the SW inverters. See Figure 2-7 for the location of the communications port on the GTI circuit board.



NOTE: The communications cables are not interchangeable. Make sure that you connect the communications cable from the inverter to the GTI that has that inverter's AC HOT IN 1 connection.

1. Connect the communications cable from inverter 1 to the communications port on GTI-1.
2. Connect the communications cable from inverter 2 to the communications port on GTI-2.

Operating Stacked Inverters

Stacked inverters must operate together in order to provide the 120/240 VAC to the loads. The Series Stacking Interface cable ensures the output from each inverter is 180 degrees out-of-phase for operating 240 VAC loads.



NOTE: Until the units are tested, do not connect loads to the inverters 120 or 240 VAC output.

Start-up and Test

1. Ensure the main service panel's circuit breakers feeding the inverters are OFF.
2. Switch ON both inverters. The inverter should be providing 120/240 VAC to the sub-panel.
3. Use an AC voltmeter and measure the voltage between the L1 terminal and neutral bus in the sub-panel. This voltage should be 120 VAC ($\pm 3\%$).
4. Measure the voltage between the L2 terminal and neutral bus in the sub-panel. This voltage should be 120 VAC ($\pm 3\%$).
5. Measure the voltage between the L1 and L2 terminals in the sub-panel. This voltage should be 240 VAC ($\pm 3\%$).
6. Switch ON the main service panel's circuit breakers feeding the inverters.
7. Verify the inverters are charging the batteries and powering the sub-panel (refer to the operator's manual).
8. Switch both inverters OFF.
9. Replace all covers and panels on the inverters and sub-panel.

The stacked inverter system is now ready for use.



NOTE: If the inverters are not operating properly, please refer to the operator's manual for setup and troubleshooting information.

2.0 INSTALLATION

Wiring Check

Before powering ON the GTI, recheck all wiring and ensure it is connected to the proper terminals. Check that the ground and neutral connections are properly wired and tight.

After all the wiring has been checked, install the front cover and secure it with the four phillips screws removed in the beginning of the installation.

Symptom	Recommended Action	Resolution
	Remove top cover and check LED on vertical circuit board (See Figure 2-6 for location of LED).	If the LED is ON, double-check all wiring from the GTI to the inverter for appropriate connections.
	If the LED is ON, the grid is functioning within acceptable parameters.	
AC1 LED on inverter is not flashing or ON solid.	If the LED is flashing, then voltage and frequency is present, but the grid is not functioning within acceptable parameters.	If the LED is flashing or OFF, contact your local utility.
	If the LED is OFF, then there is no voltage and frequency present.	If the LED is flashing or OFF, contact your local utility.

3.0 TROUBLESHOOTING

Notes:

APPENDIX A – SPECIFICATIONS

ELECTRICAL SPECIFICATIONS¹

Utility Interactive Protection	Over/under AC voltage and frequency detection plus active islanding detection
AC Voltage (Nominal)	120 VAC
AC Voltage (Allowed)	
Utility Interactive Mode	106 - 132 VAC
Bypass mode	80-149 VAC
Input Frequency (Allowed)	
Utility Interactive Mode	59.3 - 60.5 Hz
Bypass Mode	53.0 - 67.0 Hz
AC Current (Allowed) (@ 25°C)	
Utility Interactive Mode	40 amps continuous
Bypass Mode	60 amps continuous
Total Output Harmonic Distortion	
Rated	<5% at rated power
Typical	2.5% at rated power

MECHANICAL SPECIFICATIONS

Enclosure Type	Indoor, ventilated, steel chassis with white, powder-coat finish
Unit Weight	26 lb (15.9 kg)
Dimensions (H x W x D)	6.3" x 21" x 7" (16 cm x 53.3 cm x 17.8 cm)
Mounting	wall mount in a horizontal position only
AC Input/Output Terminals	Sized for #2-#14 AWG wires
Conduit Sizes	Dual ¾" - 1" and ½" - ¾" knockouts

Specifications @ 25 °C
Specifications subject to change without notice.



¹All electrical specifications are based on the unit operating in the Utility Interactive Mode (SELL Mode selected) unless otherwise specified.



Note: Bypass Mode refers to all SW operating modes (FLT/SLT/LBX) other than Utility Interactive Mode.

APPENDIX A - SPECIFICATIONS

APPENDIX B – PRODUCT AND SYSTEM INFORMATION

WARRANTY

Xantrex Technology Inc., warrants its power products against defects in materials and workmanship for a period of two (2) years from the date of purchase, established by proof of purchase or formal warranty registration, and extends this warranty to all purchasers or owners of the product during the warranty period. Xantrex does not warrant its products from any and all defects:

- arising out of material or workmanship not provided by Xantrex or its Authorized Service Centers;
- when the product is installed or exposed to an unsuitable environment as evidenced by generalized corrosion or biological infestation;
- resulting from abnormal use of the product, alteration, or use in violation of the instructions;
- in components, parts, or products expressly warranted by another manufacturer.

Xantrex Technology Inc., agrees to supply all parts and labor to repair or replace defects covered by this warranty with parts or products of original or improved design, at the company's option. Xantrex Technology Inc., also reserves the right to improve the design of its products without obligation to modify or upgrade those previously manufactured. Defective products must be returned to Xantrex Technology Inc., or its Authorized Service Center in the original packaging or equivalent. The cost of transportation and insurance on items returned for service is the responsibility of the customer. Return transportation (UPS Ground or equivalent) as well as insurance on all repaired items is paid by Xantrex Technology Inc.

All remedies and the measure of damages are limited to the above. Xantrex Technology Inc., shall in no event be liable for consequential, incidental, contingent, or special damages, even if Xantrex Technology Inc., has been advised of the possibility of such damages. Any and all other warranties, expressed or implied, arising by law, course of dealing, course of performance, usage of trade or otherwise, including, but not limited to, implied warranties of merchantability and fitness for a particular purpose, are limited in duration for a period of two (2) years from the original date of purchase.

Some states or countries do not allow limitations on the term of an implied warranty, or the exclusion or limitation of incidental or consequential damage, which means the limitations and exclusions of this warranty may not apply to you. Even though this warranty gives you specific legal rights, you may also have other rights which vary from state to state.

APPENDIX B – PRODUCT & SYSTEM INFORMATION

RETURN MATERIAL AUTHORIZATION POLICY

You must obtain a Return Material Authorization (RMA) number from Xantrex before returning a product directly to Xantrex. Products returned without an RMA number or shipped collect will be refused. When you contact Xantrex to obtain service, be prepared to supply the serial number of your product and its date of purchase as well as information about the installation and use of the unit.

Return Material Procedure

If you are returning a product, follow this procedure:

1. Obtain an RMA number and a shipping address from Xantrex.
2. Package the unit safely, preferably using the original box and packing materials. Include the following:
 - The RMA number
 - A copy of your dated proof of purchase
 - A return address where the repaired unit can be shipped
 - A contact telephone number
 - A brief description of the problem
3. Ship the unit freight prepaid to the address provided in step 1.

APPENDIX B – PRODUCT & SYSTEM INFORMATION

SERVICE INFORMATION

Xantrex Technology Inc., takes great pride in its products and makes every effort to ensure your unit fully meets your independent powering needs.

If your product needs repair, contact our Customer Service department at: (360) 435.8826 to obtain an RMA# and shipping information; or, fax this page with the following information to: (360) 474.0616.

Please provide:

Model Number: _____

Serial Number: _____

Purchase Date: _____

Problem: _____

Include a telephone number where you can be reached during business hours and a complete return shipping address (P.O. Box numbers are not acceptable).

Name: _____

Address: _____

City: _____

State / Province: _____

Zip / Postal Code: _____

Country: _____

Phone: (____) _____

FAX: (____) _____

E-mail Address: _____

APPENDIX B – PRODUCT & SYSTEM INFORMATION



xantrex

Smart Choice for Power

t 1 360 435 8826

f 1 360 435 2229

dpm@xantrex.com

www.xantrex.com